

HYPRO®**SEAL REPLACEMENT AND
PUMP HOUSING ASSEMBLY**

1. Install slinger ring on engine shaft.
2. Lubricate and install the o-ring around back side of metal portion of the seal (See Figure 1). Insert the stationary portion of the new mechanical seal by carefully pushing only on the outer metal ring as you press it into the casing cover. Use a tool with 1-1/2" ID, such as 1-1/2" diameter PVC pipe, 4" long that fits over the carbon face of the seal, but pushes only on the metal ring to insert the seal. The carbon surface of the seal must be facing you during installation. Be careful to avoid scratching the seal's carbon surface. (See Figure 2.)
3. Apply medium strength (Blue) threadlocker onto the (4) engine mounting bolts and install about (4) turns into the engine. Install the pump flange by sliding over the engine shaft 45 degrees clockwise from the up position. Once the flange has mated to the engine, rotate the flange 45 degrees counter-clockwise (CCW) to lock the flange into the slots. Tighten the (4) mounting bolts with a 13mm wrench to a torque of 10 foot pounds.
Note: Be sure to hold the pump flange in the "UP" position when tightening bolts. This will ensure that the pump bases will not be cocked off center in the final assembly. (See Figure 3.)
4. Lubricate the seal cavity of the impeller with WD-40, LPS or equivalent, and carefully press the seal's mating ceramic ring in place, seating it squarely on the bottom of the cavity. The glossy, finished side of the ceramic seal must be facing you. **IMPORTANT:** Make sure both seal surfaces are clean and lubricated. Never run seal surfaces dry. (See Figure 4.)
5. Install the impeller onto the engine shaft using the bolt, washer and seal. Bolt seal must not be worn. Tighten the impeller bolt to 10 foot pounds. (See Figure 5.)
6. Install diffuser onto the casing cover with three Phillips-head screws.
7. Install the pump casing onto the casing cover and o-ring, and secure with the 10 bolts, nuts and washers, using a 10mm socket and wrench. Torque the bolts to 45 inch pounds.
8. Once assembly is complete, pull on the engine recoil starter with engine switch in the "OFF" position to verify that the impeller rotates smoothly without catching. Connect spark plug wire. Assembly and inspection is now complete.



Fig. 1

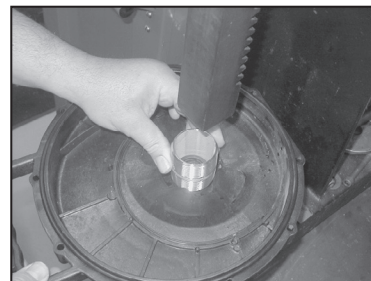

Fig. 2

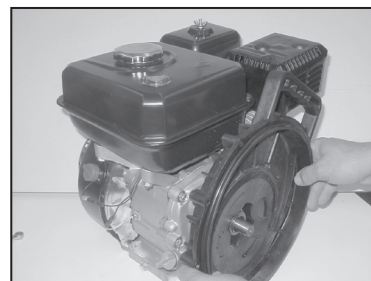

Fig. 3

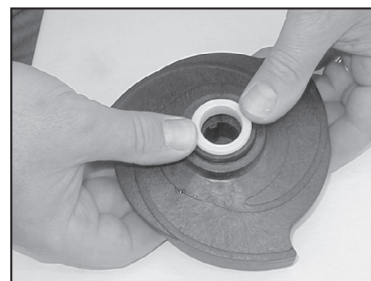

Fig. 4

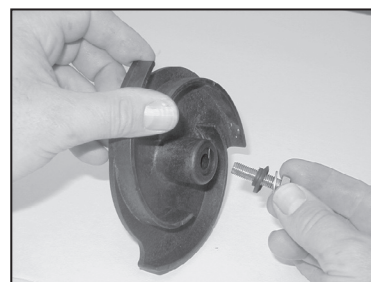
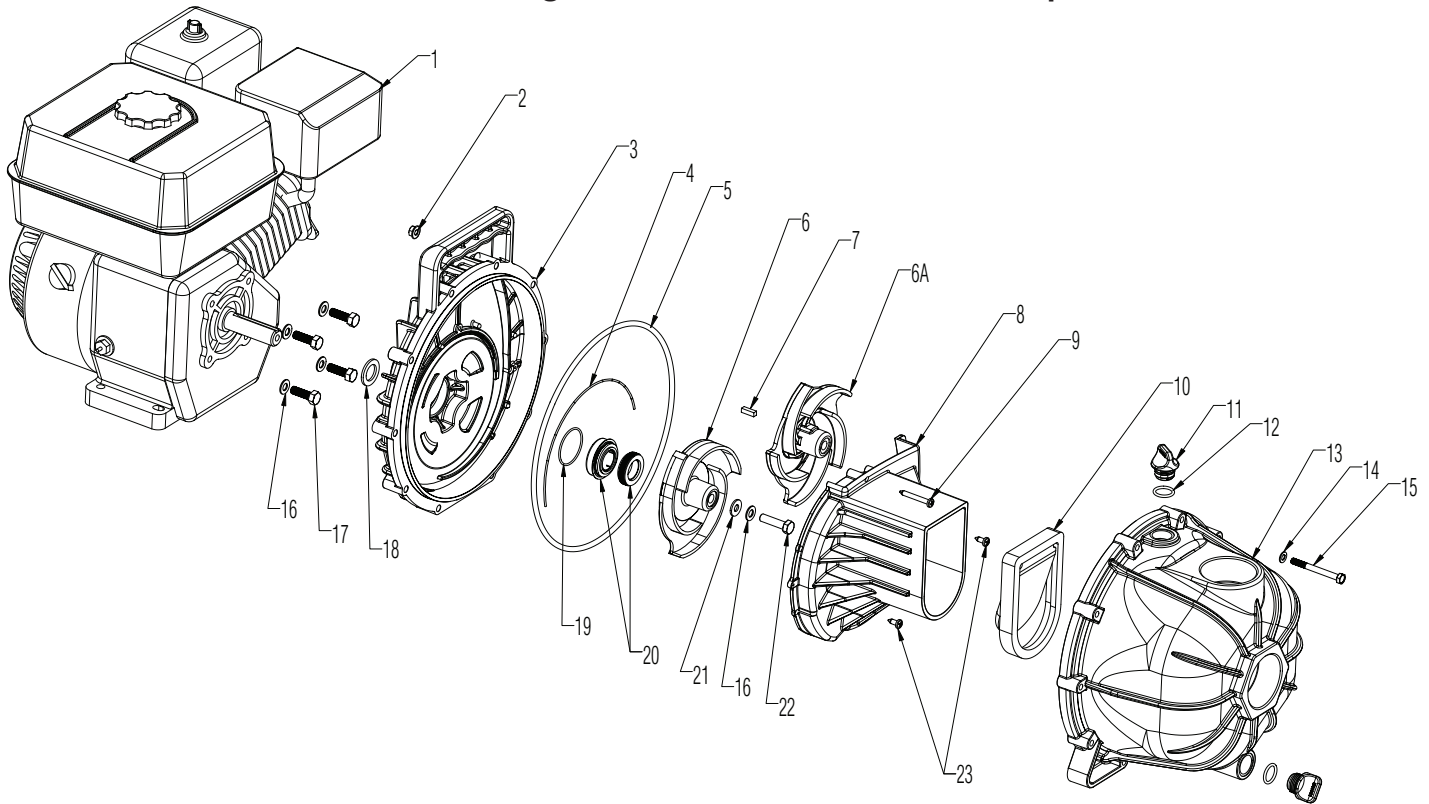

Fig. 5

1542P-3SP, 1542P-5SP Gasoline Engine-Driven Plastic Transfer Pump



Seal Repair Kit 3430-0635 contains:

(1) Ref. 4 Diffuser Gasket, (1) Ref. 5 Pump Body O-Ring, (1) Ref. 19 Seal O-Ring, (1) Ref. 20 Mechanical Seal, and (1) Ref. 21 Impeller Gasket

Viton Seal Repair Kit 3430-0659 contains:

(1) Ref. 4 Diffuser Gasket, (1) Ref. 5 Pump Body O-Ring, (1) Ref. 10 Flapper Valve, (1) Ref. 19 Seal O-Ring, (1) Ref. 20 Mechanical Seal, and (1) Ref. 21 Impeller Gasket

Pump Head Kit 3430-0637 (1542P-3SP) Includes all items less 1, 6A and 7.

Pump Head Kit 3430-0648 (1542P-5SP) Includes all items less 1 and 6.

Optional Viton Pump Head Kit 3430-0660 (1542P-3SP) Includes all items less 1, 6A and 7.

Optional Viton Pump Head Kit 3430-0661 (1542P-5SP) Includes all items less 1 and 6.

Ref# Spec.	Torque
#17	10 ft-lbs.
#22	10 ft-lbs.
#15	45 in-lbs.

REF. NO.	QTY.	PART NO.	DESCRIPTION
1	1	2549-0039	5.5 HP PowerPro Gas Engine (1542P-3SP)
1A	1	2549-0041	6.5 HP PowerPro Gas Engine (1542P-5SP)
2	10	2250-0087	Hex Flange Nut, M6
3	1	0750-1540P	Mounting Flange
4	1	1700-0209	Diffuser Gasket
5	1	1720-0229	Pump Body O-Ring
6	1	0400-1540P	3 Vane Impeller (1542P-3SP)
6A	1	0401-1540P	5 Vane Impeller (1542P-5SP)
7	1	1610-0044	Key 3/16 X 5/8 SS (1542P-5SP)
8	1	0150-1540P	Diffuser
9	1	2210-0144	Diffuser Mounting Screw (Long)
10	1	1700-0208	Flapper Valve
11	2	2404-0350P	Fill/Drain Plug

REF. NO.	QTY.	PART NO.	DESCRIPTION
12	2	1720-0035	Plug O-Ring
13	1	0100-1540P	Pump Housing
14	10	2270-0115	Flat Washer 6M
15	10	2210-0141	Bolt 6M X1 X 60
16	5	2270-0114	Washer 5/16 SS
17	4	2210-0143	Mounting Bolt 5/16-24 X 1
18	1	1410-0083	Slinger Ring
19	1	1720-0231	Seal O-Ring
20	1	2120-0044	Mechanical Seal
21	1	1700-0210	Impeller Gasket
22	1	2210-0142	Impeller Bolt 5/16-24 X 1-1/4
23	2	2210-0145	Diffuser Mounting Screw (Short)

